



## LW Series Foam Chambers



WILLIAMS FIRE & HAZARD CONTROL LW Series Foam Chambers consist of a foam expansion chamber and an integral foam maker, defined by NFPA 11 as “Type II” top-side application device. The foam chamber is installed inside a flammable liquid storage tank above the product’s highest liquid level. The chambers are designed to meter foam flow, then gently expand and deliver foam directly onto the surface of a flammable or combustible liquid. The foam solution is piped to the chamber from outside the hazard area. Upon entering the chamber, the foam solution is expanded and then discharged against a deflector inside the storage tank. The deflector directs the foam against the inside wall of the storage tank. This reduces the submergence of the foam and agitation of the fuel surface. (NFPA Type II Application)

Flow rates are sized for full surface application, or for protection of the annular seal area. Foam solution supply piping to the chamber can either be connected to a “fixed” foam storage and proportioning system, or tied into a dry pipe, “semi-fixed” system which receives foam solution from a mobile foam apparatus.

In operation, foam solution passes through an orifice plate which is sized to deliver the required flow rate at a specific inlet pressure. The metered flow of foam solution is then introduced into the foam maker, where it is aerated. The foam chamber inlet piping is fitted with a frangible vapor seal, which is designed to rupture at a predetermined pressure. The aerated foam solution enters the foam expansion chamber body, where additional expansion occurs, and the velocity of the foam is reduced. As the foam leaves the chamber body, it passes through the tank shell, and then impacts the foam deflector, which directs the foam down the tank wall and ultimately onto the fuel surface.

The foam chamber is accessible for inspection and service through a removable inspection hatch which is located on top of the chamber body. Foam deflectors are available in either split (as a standard) or shallow configurations. Split-style deflectors allow for installation when the deflector location is only accessible from outside the tank

(existing tank installations, etc.), but can be used elsewhere. Shallow style deflectors are useful when only a small space between the foam dam or tank rim is available and a normal deflector may come into contact with part of the floating roof. All foam chambers are supplied with standard finish, primed with red epoxy exterior coating.

### LW Series Foam Chamber Models

Model	Nominal Flow	Inlet Flange	Outlet Flange
LW-9	40 – 150 gpm (151 – 568 Lpm)	2.5"	4"
LW-17	100 – 280 gpm (379 – 1,060 Lpm)	3"	6"
LW-30	190 – 600 gpm (719 – 2,271 Lpm)	4"	8"
LW55	400 – 1,000 gpm (1,514 – 3,785 Lpm)	6"	10"

#### Notes:

Operational inlet pressure for foam chambers is 50 psi (3.4 bars) to 100 psi (6.9 bars). Pressures outside of that range require engineering approval.

## Product Specifications

Materials of Construction	
Body, Maker and Flanges	Carbon Steel
Retainer Hatch	Stainless Steel and Brass
Orifice Plate	Stainless Steel
Retainer, Vapor Seal	Brass

### Exploded View and Nominal Dimensions of LW Series Foam Chambers

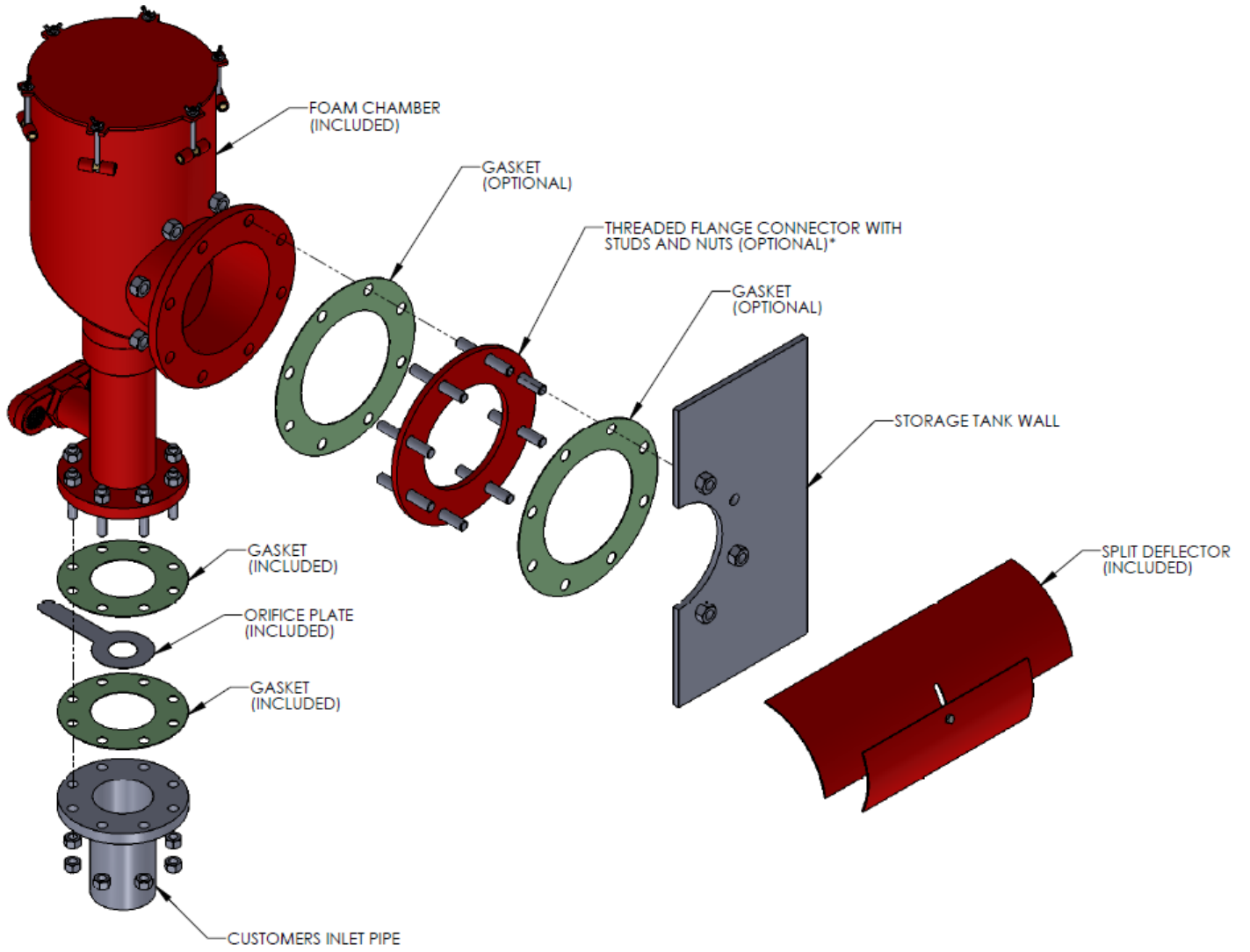

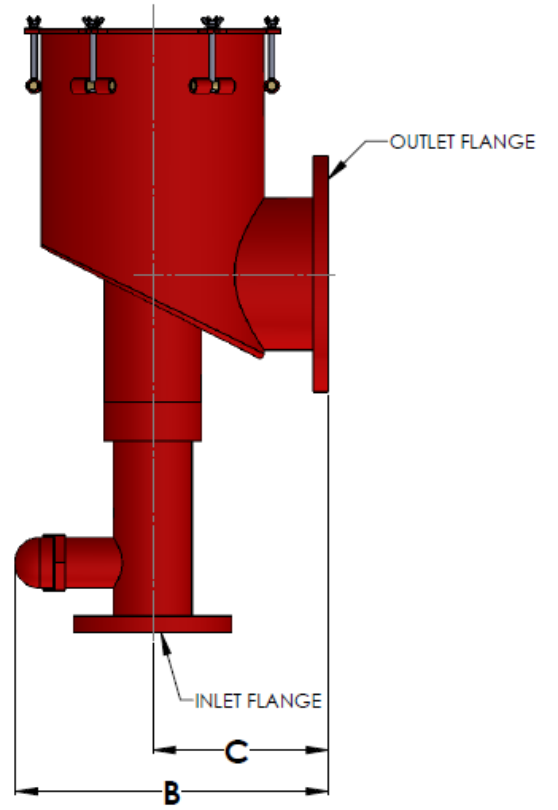
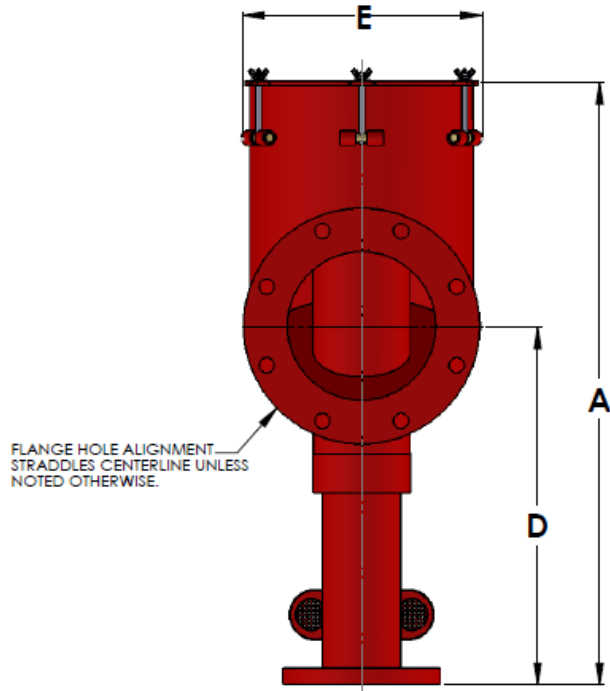

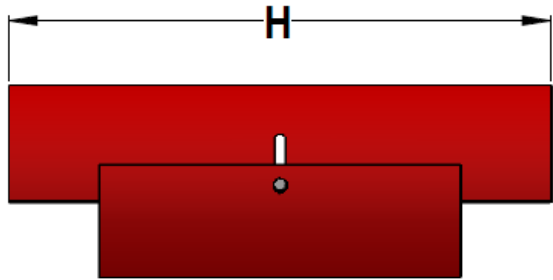

**SPLIT DEFLECTOR**

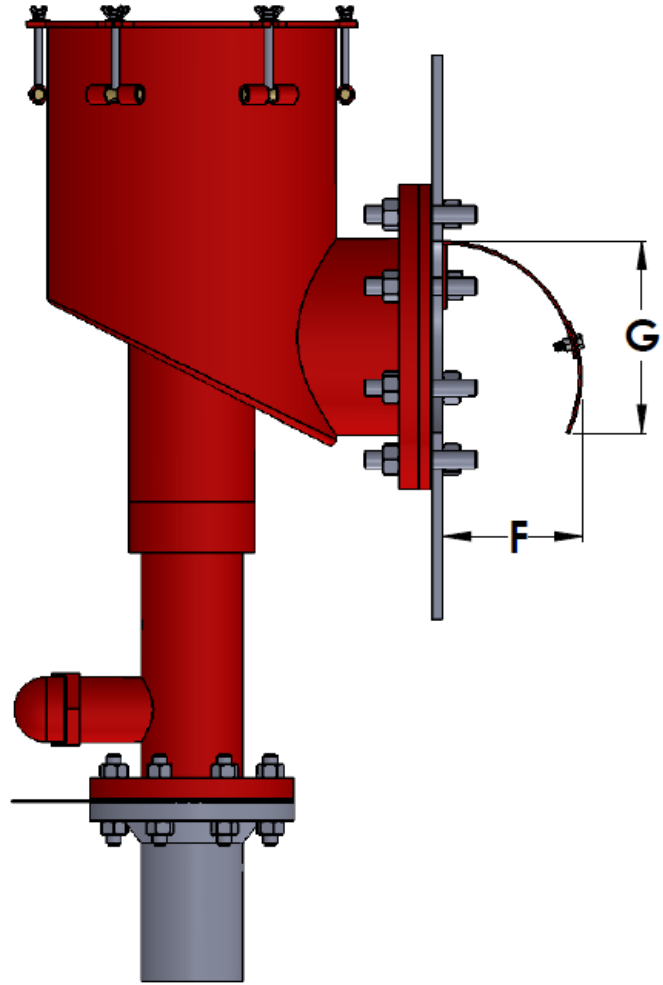

	A	B	C	D	E	F	G	H	INLET FLANGE	OUTLET FLANGE	WEIGHT
LW9	28-1/2	12-1/4	7	18	10-1/4	3	5	12	2-1/2" 150 LB	4" 150 LB	80 LBS
LW17	32	15-1/2	9	19-1/2	12-1/2	4-3/4	5	18	3" 150 LB	6" 150 LB	130 LBS
LW30	34-1/4	17-3/4	10	20-1/2	13-3/4	6	9	24	4" 150 LB	8" 150 LB	200 LBS
LW55	42	21	12	25	16-3/4	6-3/4	12	30	6" 150 LB	10" 150 LB	350 LBS

**Notes:**

1. Standard foam chambers supplied with split deflectors. Solid and shallow deflectors available upon request.
2. "H" dimensions for split and solid foam deflectors is the same.
3. 1/2" tank wall thickness assumed for sizing threaded flange connectors stud length.

4. All dimensions in inches.

5. All dimensions are nominal.

## Ordering Information

Part Number	Model Number	Deflector Type
10715	LW-9	Shallow
10713	LW-9	Split
10723	LW-17	Shallow
10721	LW-17	Split
10730	LW-30	Shallow
10728	LW-30	Split
10738	LW-55	Shallow
10736	LW-55	Split

### Notes:

Foam chamber size, number of foam chambers required, deflector type and orifice size are project dependent.

When ordering, please provide following information:

- Product in storage tank
- Tank configuration
- Tank diameter
- Full surface or seal protection
- Height of foam dam (seal protection)

### LW Series Foam Chamber Accessories

Part Number	Description
10667	LW-9 foam chamber outlet mounting flange assembly, kit
14996	No-blow vapor seal kit for LW-9, stainless steel
10699	LW-17 foam chamber outlet mounting flange assembly, kit
14997	No-blow vapor seal kit for LW-17, stainless steel
10704	LW-30 foam chamber outlet mounting flange assembly, kit
14998	No-blow vapor seal kit for LW-30, stainless steel

10708	LW-55 foam chamber outlet mounting flange assembly, kit
14999	No-blow vapor seal kit for LW-55, stainless steel